

KENSOL 65

8 TON
AIR-OPERATED
 ROLL LEAF STAMPING PRESS

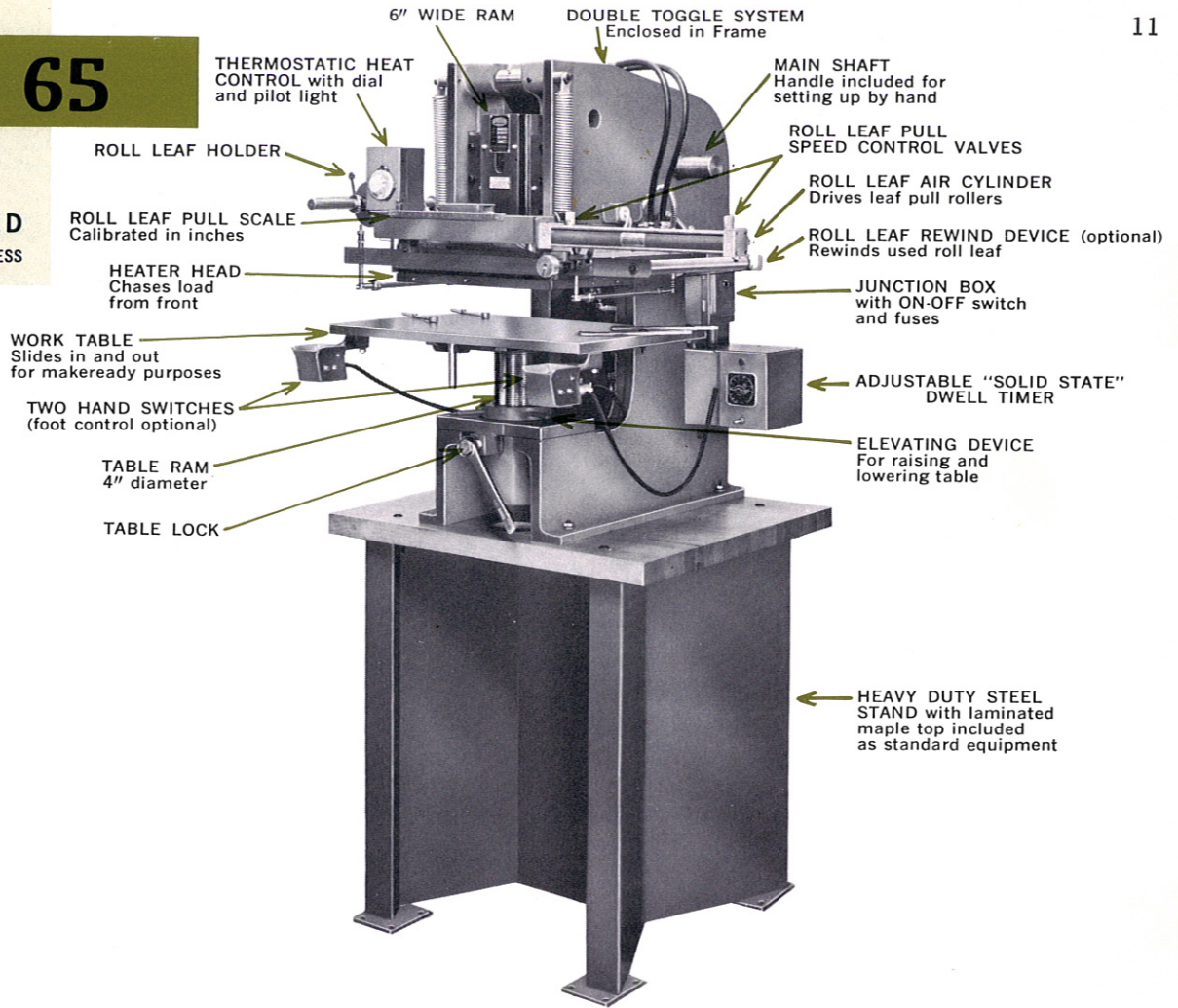

The Kensol 65 eight ton, double toggle roll leaf stamping press is a completely new design. This open frame machine has a broad 6" ram for maximum rigidity. The eight tons of pressure developed is sufficient for 95% of all production hot stamping work. The 65 will take items up to six inches high and has a deep 9" throat. Standard equipment includes: a heavy duty steel stand with a laminated maple top, a new solid state dwell timer, sturdy 4 inch diameter table ram, roll leaf pull speed control and delay valves to

insure proper leaf stripping, and a front loaded heater head for ease in changing type and dies.

Standard heater heads and roll leaf attachments are 6 x 8, 6 x 12, and 10 x 15 inches. Special larger sizes, "criss-cross" feeds, etc. can be made to suit your requirements. Power slide tables, turntables and other feeding devices are available.

DIMENSIONS:

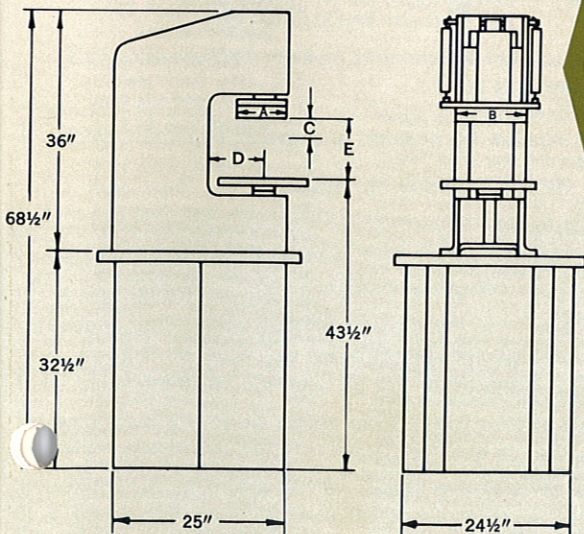

SPECIFICATIONS:

(letters before the more important dimensions pertain to the diagrams at left)

- IMPRESSION AREA • DIRECTION OF AUTOMATIC ROLL LEAF PULL
- (A) 6 x (B) 8 Inches Left to Right Air-Operated Pull
- (A) 6 x (B) 12 Inches Left to Right Air-Operated Pull
- (A) 10 x (B) 15 Inches Left to Right Air-Operated Pull

Special larger heater heads and roll leaf attachments made to your specifications.

- HEAD STROKE: (C) 3 Inches
- DEPTH OF THROAT: (D) 9 Inches
- MAXIMUM OPENING (with head in up position): (E) 9 Inches
- WILL HOT STAMP ITEMS UP TO 6 INCHES HIGH

PRESSURE RANGE: Up to 8 Tons

WORKTABLE: 1/2" x 12" x 14" standard with 6" x 8" and 6" x 12" heads
 3/4" x 16" x 24" standard with 10" x 15" head
 Both slide out by hand for makeready purposes.

HEATING SYSTEM:

- 2-500 Watt cartridge heaters in the 6 x 8 inch head, 1000 Watt total
- 3-400 Watt cartridge heaters in the 6 x 12 inch head, 1200 Watt total
- 4-600 Watt cartridge heaters in the 10 x 15 inch head, 2400 Watt total

THERMOSTAT: Robertshaw 0-550° F., complete with dial and pilot light, standard.
 A.P.I. electronic with module, optional at extra cost.

DWELL TIMER (SOLID STATE): 0-5 Seconds, complete with ON-OFF switch, dial and pilot light.

CONTROLS: Two hand switches, with no tie down feature, standard. Foot control, also available.

ELECTRICAL REQUIREMENTS: 110 Volts A.C. or 220 Volts A.C. 220 Volts A.C. recommended on the 10 x 15 inch and larger heads.

COMPRESSED AIR REQUIREMENTS: 9 CFM at 100 pounds pressure (or a 2 H.P. compressor)

DIMENSIONS: 30" wide x 30" deep x 68 1/2" high.

WEIGHT: 1,100 pounds net (10 x 15 inch Press, uncrated)