

*The Stamp of  
Perfection...  
For the Image  
of Tomorrow*

The newest generation of hot stamp machines embodies the versatility, reliability, and safety characteristics that finishers demand today. Advanced design features and a wide selection of options assure unmatched productivity and part quality. From "stand alone" machines to totally automated turnkey operations, from rubber dies and rollers to complete tooling systems, United Silicone is your single source for the latest developments in hot stamping technology.



**UNITED  
SILICONE**

A high performance hot stamper engineered for years of trouble-free use, the US-10 features durable, steel C-Frame construction, maximum head stability, and quick-change die mounting. Digitally controlled electric foil feed and instant spent foil removal reduce downtime. Three head sizes are standard.

### Standard Features

- Head cylinder rod dia. - 2½" for greater stability
- Manually operated head height adjustment
- Vernier-calibrated positive depth stop control - no pinch points
- Electric foil feed - digital control - side to side
- Foil jog
- Foil pull selector
- Instant spent foil removal
- Solid state heat control
  - 0 to 999 degrees F
  - 0 to 540 degrees C
- Digital dwell control 0.1 to 99.9 seconds
- Digital cycle counter - resets to 0
- Simultaneous anti-tiedown buttons with pinch point circuit

### Specifications

- Stamping pressure at 80 psi 1 ton
- Stamping head size
  - 6" x 6" - 1600 Watts
  - 6" x 8" - 2100 Watts
  - 6" x 10" - 2600 Watts
- Stroke of stamping head 0-2"
- Working height 0-11½"
- Throat depth 6¾"
- Overall dimensions
  - 23" wide
  - 20" long
  - 40" high
- Worktable dimensions 12" x 12"
- Electrical requirement
  - 110 V AC Standard
  - 220 V AC Optional
- Air requirement 12 CFM
- Weight 400 lbs.

### Options

- Extra clearance under head (6" Increments)
- Electrical interlocked safety gate
- Slide table - pneumatic
- Rotary table - pneumatic
- Rotary table - electro mechanical
- Floor stand table - 32" high x 30" deep x 48" wide

In keeping with its policy of continuous product improvement, United Silicone reserves the right to discontinue or change specifications, designs, materials and equipment without notice or obligation, consistent with sound engineering principles and modern practices.

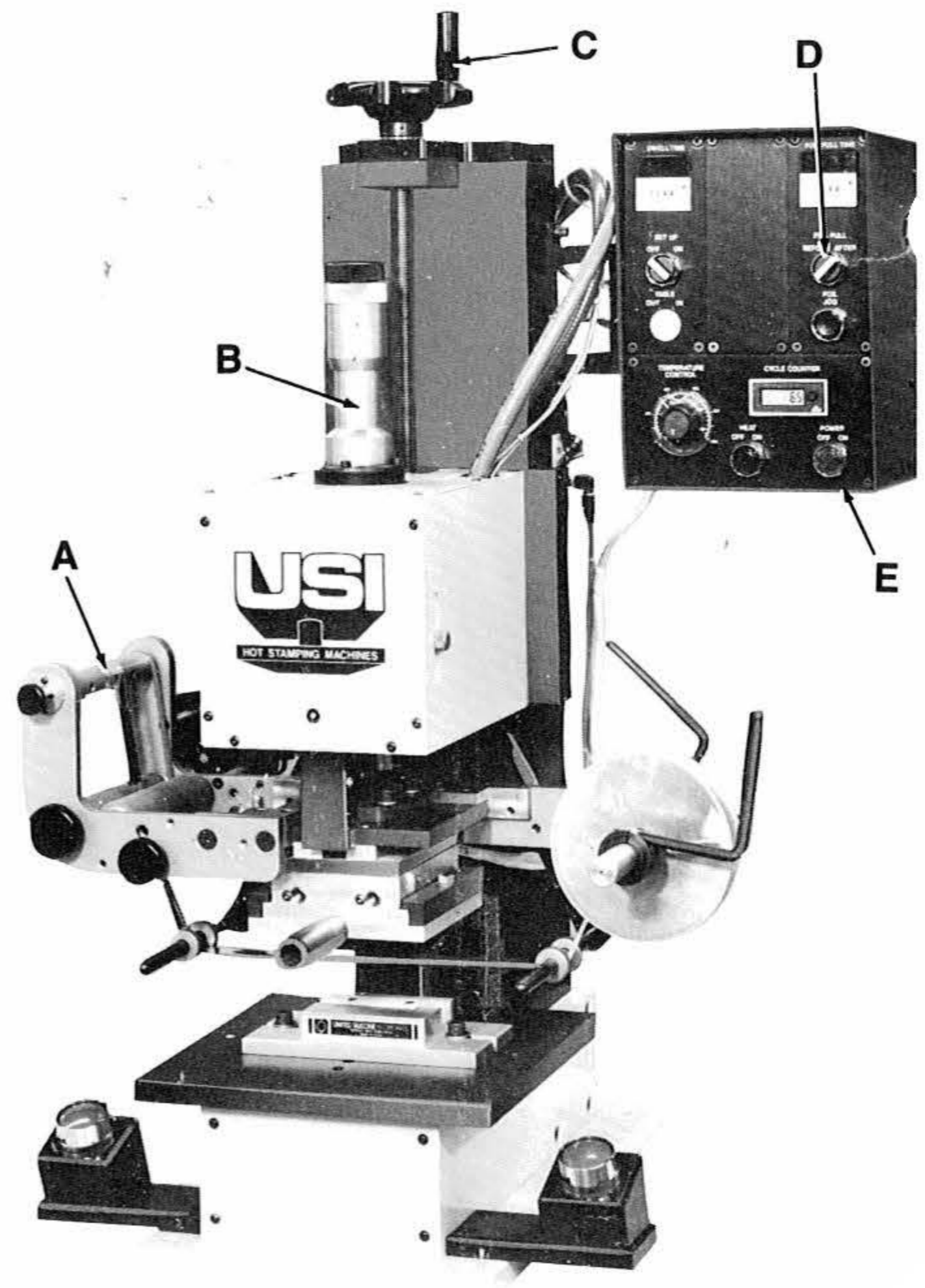

A) Instant Spent Foil Removal  
 B) Vernier Calibrated Depth Stop Control  
 C) Manual Head Height Adjustment  
 D) Foil/Pull  
 E) Easy Access Controls

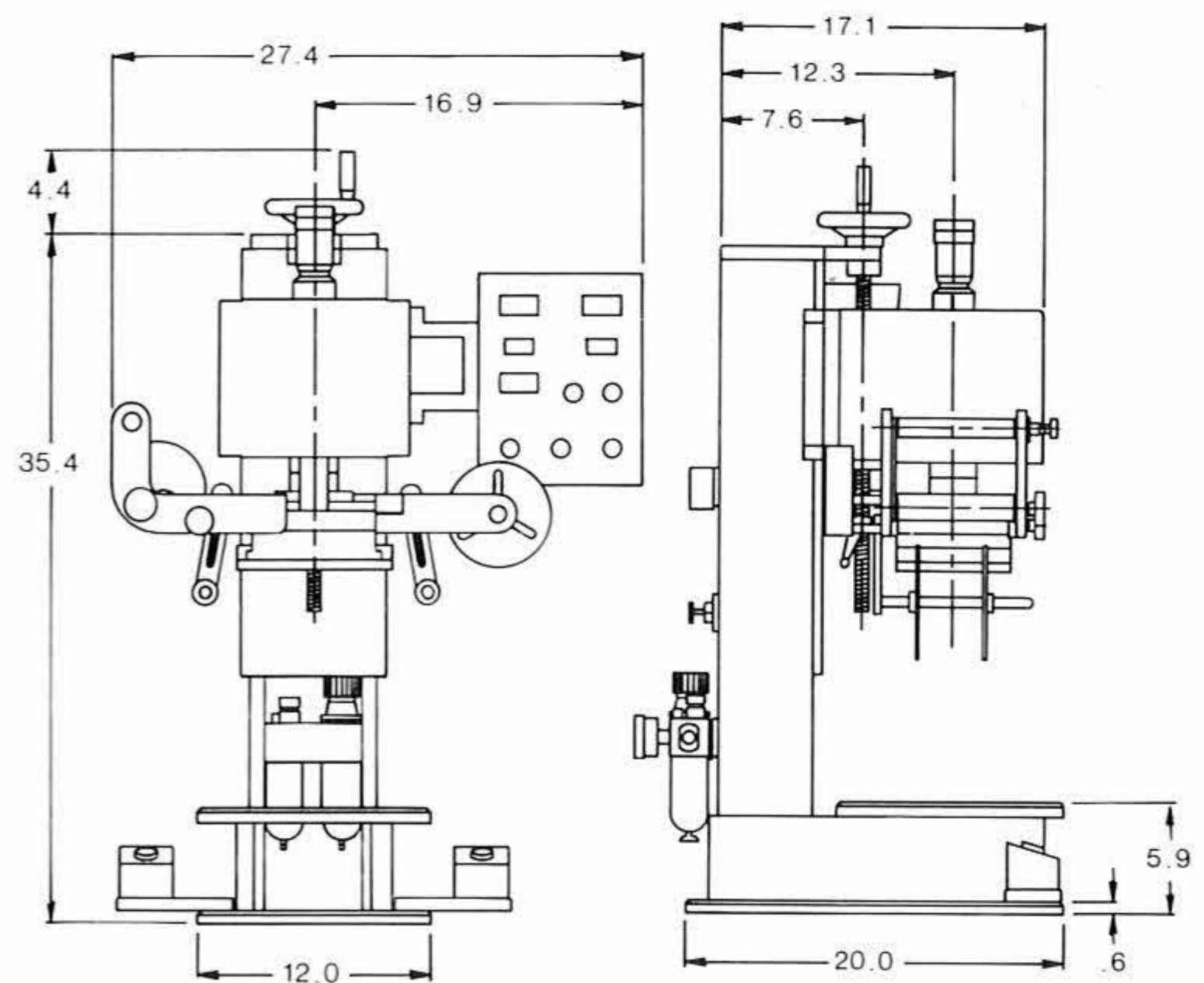

**U.S.A.:**  
 United Silicone Incorporated  
 4471 Walden Ave., P.O. Box 265  
 Lancaster (Buffalo), N.Y. 14086  
 Phone: (716) 681-8222  
 Telex: 92-210  
 FAX: (716) 681-8789

**U.S.A.:**  
 United Silicone West  
 2326 N. Batavia St.  
 Unit 114  
 Orange, CA 92665  
 Phone: (714) 974-2772  
 FAX: (714) 974-0422

**BRAZIL:**  
 ICLA Industria  
 Rua Severa, 477-Vila Maria  
 Sao Paulo-CEP 02111, Brazil  
 Telephone: (011) 292-5499  
 Telex: (011) 32-758  
 FAX: 019/88