

# Kensol 36

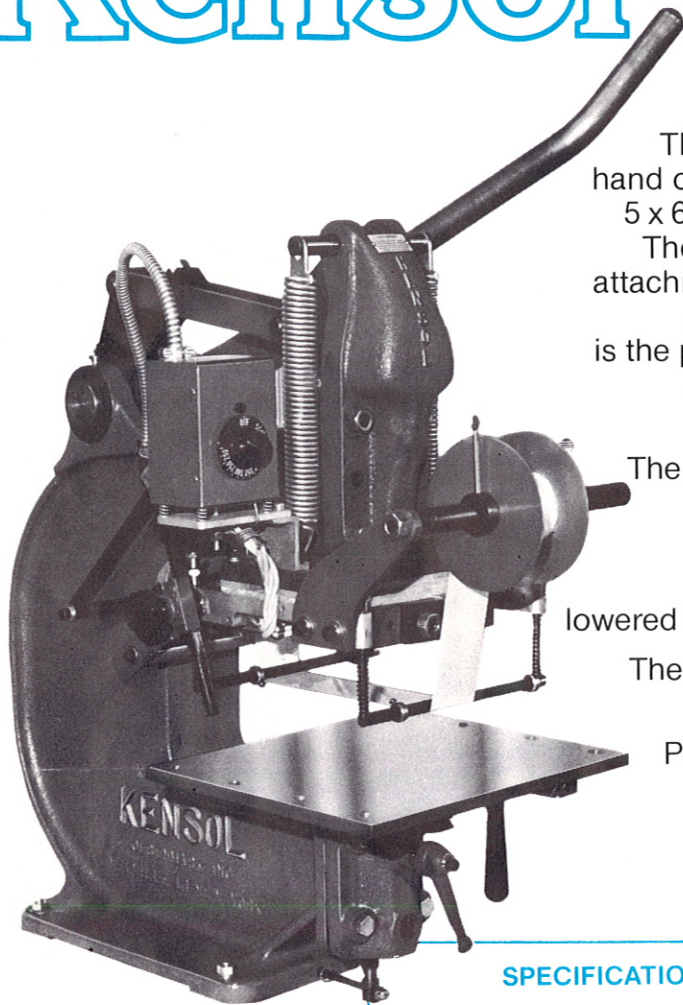

The Kensol 36 is our largest and most powerful hand operated press. This machine is available with a 5 x 6 Inch, 6 x 8 Inch, or 6 x 12 Inch impression area.

The 5 x 6 Inch version has a side to side roll leaf attachment. The 6 x 8 Inch and 6 x 12 Inch units have a front to back leaf attachment. (Shown above is the popular 6 x 8 Inch machine.) The double-toggle linkage system will develop up to three tons of head pressure.

The Kensol 36 has a long three inch head stroke so that work can be fed and taken away quickly.

A sliding table is provided for makeready purposes. This work table can be raised or lowered to accommodate items up to two inches high.

The Kensol 36 can be converted to the air-operated 36T at any time, in your own plant.

Photographs of type and die holders are shown on the reverse side.

## SPECIFICATIONS:

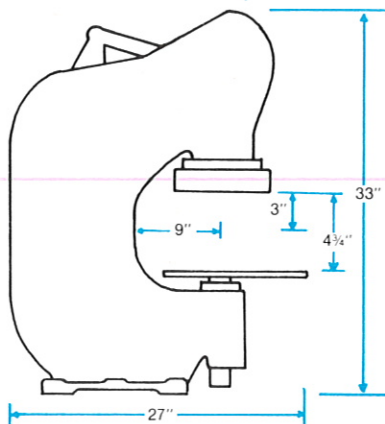

IMPRESSION AREA	DIRECTION OF AUTOMATIC ROLL LEAF PULL
5 x 6 Inches . . . . .	Right to Left (Mechanical Pull)
6 x 8 Inches . . . . .	Front to Back (Mechanical Pull)
6 x 12 Inches . . . . .	Front to Back (Mechanical Pull)
HEAD STROKE: 3 Inches	
DEPTH OF THROAT: 9 Inches. (Will stamp the center of an 18 inch wide article).	
MAXIMUM OPENING (from head to table): 5 Inches (with head in up position).	
WILL HOT STAMP ITEMS UP TO 2 INCHES HIGH. (Can be altered at factory to accept 3 inch articles)	
PRESSURE RANGE: Up to 3 Tons.	
WORK TABLE: 1/2 x 12 x 14 Inches, ground for accuracy. Slides in and out by hand for makeready purposes.	
HEATING SYSTEM:	
2—400 Watt cartridge heaters in 5 x 6 Inch head, 800 Watt total	
2—500 Watt cartridge heaters in 6 x 8 Inch head, 1000 Watt total	
2—500 Watt cartridge heaters in 6 x 12 Inch head, 1000 Watt total	
THERMOSTAT: "Robertshaw" 0-550° F, complete with dial and pilot light.	
ELECTRICAL REQUIREMENTS: 110 Volts A.C. standard. 220 Volts A.C. also available.	
DIMENSIONS: 14" wide x 28" deep x 28 1/2" high (exclusive of handle).	
WEIGHT: 314 pounds net.	

## KENSOL-OLSENMARK INC.

40 MELVILLE PARK ROAD, MELVILLE, N.Y. 11747 • PHONE: (516) 694-7773 TWX 510-224-6418

WE ALSO MANUFACTURE FOILMARK ROLL LEAF