

## ***Thermal Staking Design Guidelines***

In manufacturing products with thermoplastic components, it is often necessary to join a thermoplastic to a part of dissimilar material, whether it be metal, a dissimilar plastic, or other material. This technical information sheet provides design guidelines, configurations, and techniques for successful thermal (heat) staking.

### **GENERAL DESCRIPTION:**

Thermal staking is an assembly method that uses the controlled melting and reforming of a plastic stud or boss to capture or lock another plastic or metal component of an assembly in place.

The plastic stud protrudes through a hole in the component to be locked in place. The heated thermal tip contacts the top of

the stud, which melts and fills the volume of the tip cavity to produce a head, locking the component in place. The progressive melting of plastic under continuous pressure forms the head. When staking, the right combination of heat and pressure for the application is critical.

### **ADVANTAGES:**

- Simplification of machinery
- Reduced cost of machinery
- Multiple fastening points
- Allows higher density of welds compared to hot air cold form or ultrasonic welding
- Many different size or shaped heads can be formed

Following are descriptions and specifications for the various staking profiles.

# AFM Engineering, Inc.

## Thermal Staking Design

### DOMESTAKE - HIGH PROFILE:

- To obtain optimal results use with a boss of 0.250" or less O.D.
- Smaller head means faster weld times
- Under normal conditions this method will create a perfectly symmetrical weld
- Recommended for crystalline plastics with highly defined melting points such as 33% G.F.
- Works well with plastics with abrasive fillers and for materials that easily degrade
- Dome stakes come in two basic silhouettes: high and low
- Counter bored holes can improve the appearance of these welds
- Stronger weld but slower weld time than a low profile

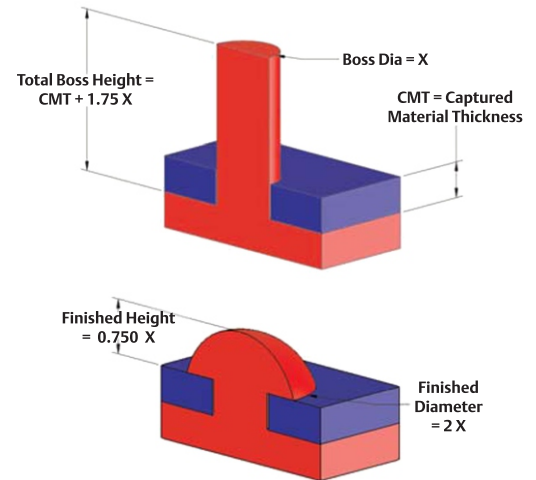

### DOMESTAKE - LOW PROFILE:

- To obtain optimal results use with a boss of 0.250" or less O.D.
- Smaller head means faster weld times
- Under normal conditions this method will create a perfectly symmetrical weld
- Recommended for crystalline plastics with highly defined melting points such as 33% G.F.
- Works well with plastics with abrasive fillers and for materials that easily degrade
- Dome stakes come in two basic silhouettes: high and low
- Counter bored holes can improve the appearance of these welds

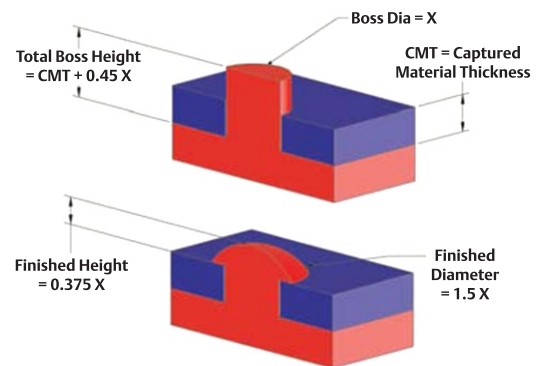

### ROSETTE STAKE - HIGH PROFILE:

- Recommended for bosses with a O.D. of 0.063" or larger
- Ideally suited for low density non abrasive plastics
- The easiest and quickest way to stake a large amount of material
- Concentration of the material is located over the welding seam
- Accuracy of stake to tip alignment is critical
- X-Y micro adjustment is essential for obtaining the proper welder stake
- Conical stakes come in two basic silhouettes: High and Low
- The welds resemblance to a rivet provides a clean aesthetic look

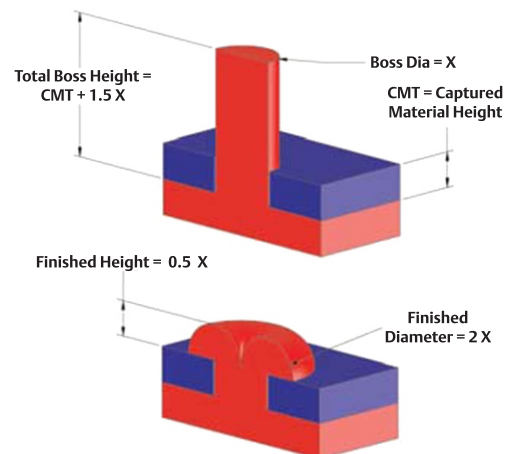

# AFM Engineering, Inc.

## Thermal Staking Design

### ROSETTE STAKE - LOW PROFILE:

- Recommended for bosses with a O.D. of 0.063" or larger
- Ideally suited for low density non abrasive plastics
- The easiest and quickest way to stake a large amount of material
- Concentration of the material is located over the welding seam
- Accuracy of stake to tip alignment is critical
- X-Y micro adjustment is essential for obtaining the proper welder stake
- Conical stakes come in two basic silhouettes: high and low
- The welds resemblance to a rivet provides a clean aesthetic look

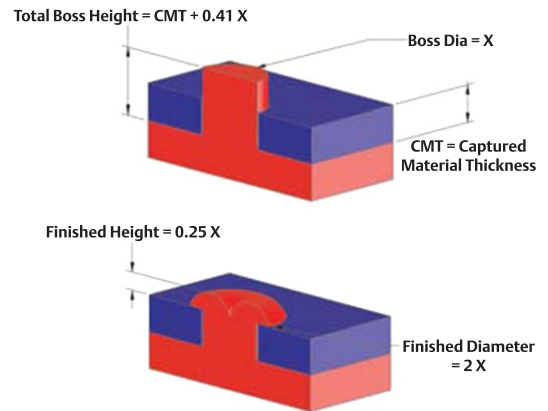

Figure 4. Rosette Stake, Low Profile

### HOLLOW STAKE:

- For best results use bosses with an 0.156" or larger O.D.
- Without having to melt large amounts of material the hollow stake will produce an extremely strong head
- Use to avoid sink marks on the opposite side of the components
- A hollow stake will enable the parts to be reassembled with a self-tapping screw for repair, or when disassembly is required
- The resemblance to a molded part gives parts a likeness once welded

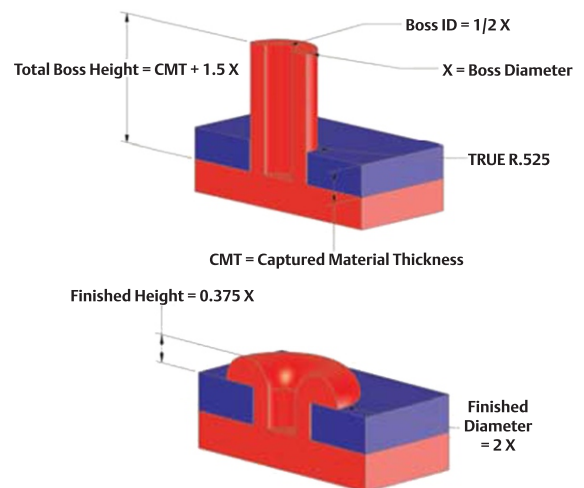

Figure 5. Hollow Stake

### KNURLED STAKE:

- A key factor in choosing the knurled staking tool is the lack of alignment that is required to produce a quality stake
- Used in applications where appearance and strength are not critical
- The configuration of the stake should be determined by the design needs
- Multiple stakes in a close proximity can be knurled by a single tool
- Normally used in conjunction with a heater platen where thermal expansion is generally a problem
- Ideally suited for production work (capable of achieving short cycle times)

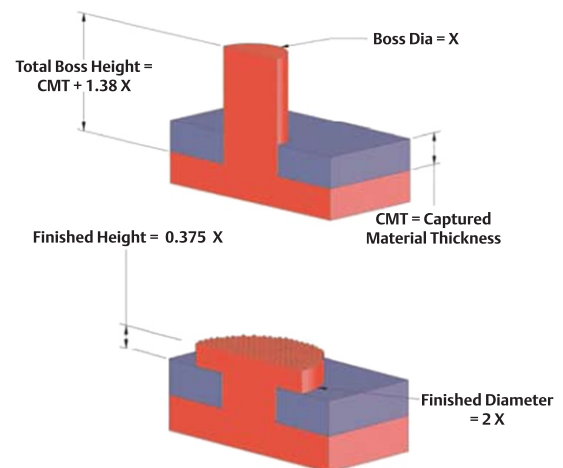

Figure 6. Knurled Stake

### KNURLED STAKE:

- A key factor in choosing the knurled staking tool is the lack of alignment that is required to produce a quality stake
- Used in applications where appearance and strength are not critical
- The configuration of the stake should be determined by the design needs
- Multiple stakes in a close proximity can be knurled by a single tool
- Normally used in conjunction with a heater platen where thermal expansion is generally a problem
- Ideally suited for production work (capable of achieving short cycle times)

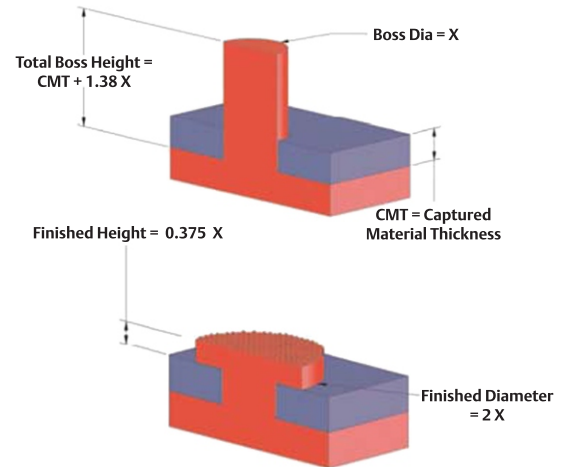

Figure 6. Knurled Stake

### FLUSH STAKE:

- Typically used for applications requiring a flush mounting surface
- Requires that mating component has sufficient thickness for a countersink, counter bore, or a combination of the two
- The volume of the boss is crucial to ensure the countersink is flush once the weld is complete

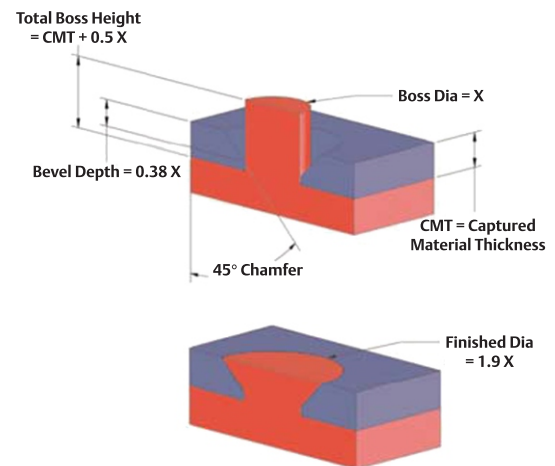

Figure 7. Flush Stake