

ITEM NO.	PartNo	DRAWING #	DESCRIPTION	QTY.
1	103125	37120-000	3X6 Heater Head	1
2	103118	59120-000	3 X 6 Dovetail	1

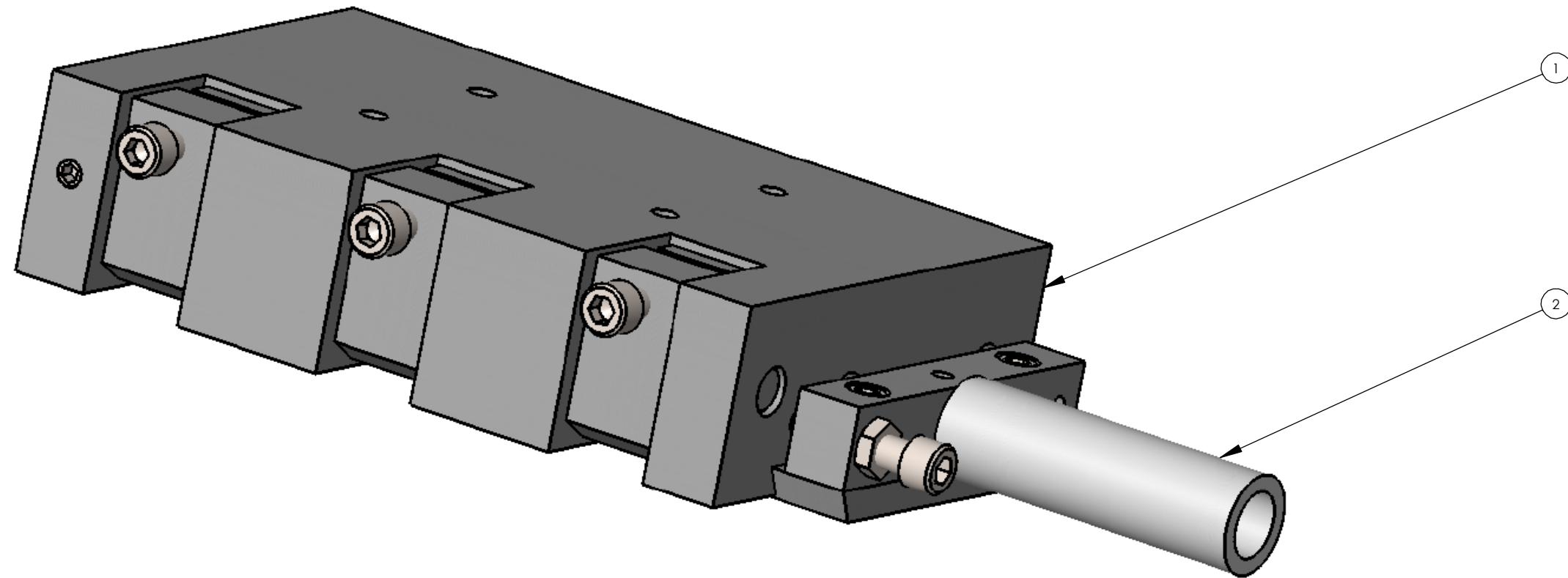

<p><b>PROPRIETARY AND CONFIDENTIAL</b></p> <p>THE INFORMATION CONTAINED IN THIS DRAWING IS THE SOLE PROPERTY OF AFM ENGINEERING, INC. ANY REPRODUCTION IN PART OR AS A WHOLE WITHOUT THE WRITTEN PERMISSION OF AFM ENGINEERING INC. IS PROHIBITED.</p>		DIMENSIONS ARE IN INCHES TOLERANCES: FRACTIONAL ± ANGULAR: MACH ± BEND ± TWO PLACE DECIMAL ± .010 THREE PLACE DECIMAL ± .005		NAME Irwin	DATE -	AFM Engineering, Inc.  <b>FRANKLIN KENSOL/FRANKLIN                  HEATER HEADS                  3X6 HEATER HEAD COMPLETE                  AFM PART # 103798</b>
		MATERIAL		CHECKED Irwin	ENG APPR. -	
		FINISH		MFG APPR. -	Q.A. -	
		NEXT ASSY USED ON		COMMENTS:		
APPLICATION	DO NOT SCALE DRAWING			SIZE DWG. NO. <b>B</b> 37120-000_With_Dovetail	REV. -	SCALE: 1:2 WEIGHT: 3.485 SHEET 1 OF 1