

S:\AFMMachines\59000 Dovetails\59100 Franklin\59150 10X15\59156-000 steel hot plate\

ITEM NO.	PART NUMBER	PartNo	DESCRIPTION	QTY.
1	59156-002_Steel_Hot_Plate	10105276	Dovetail 10 X 15 drilled for Steel Hot Plate	1
2	59156-001_Steel_Hot_Plate	105277	10"X15" Steel Hot Plate	1

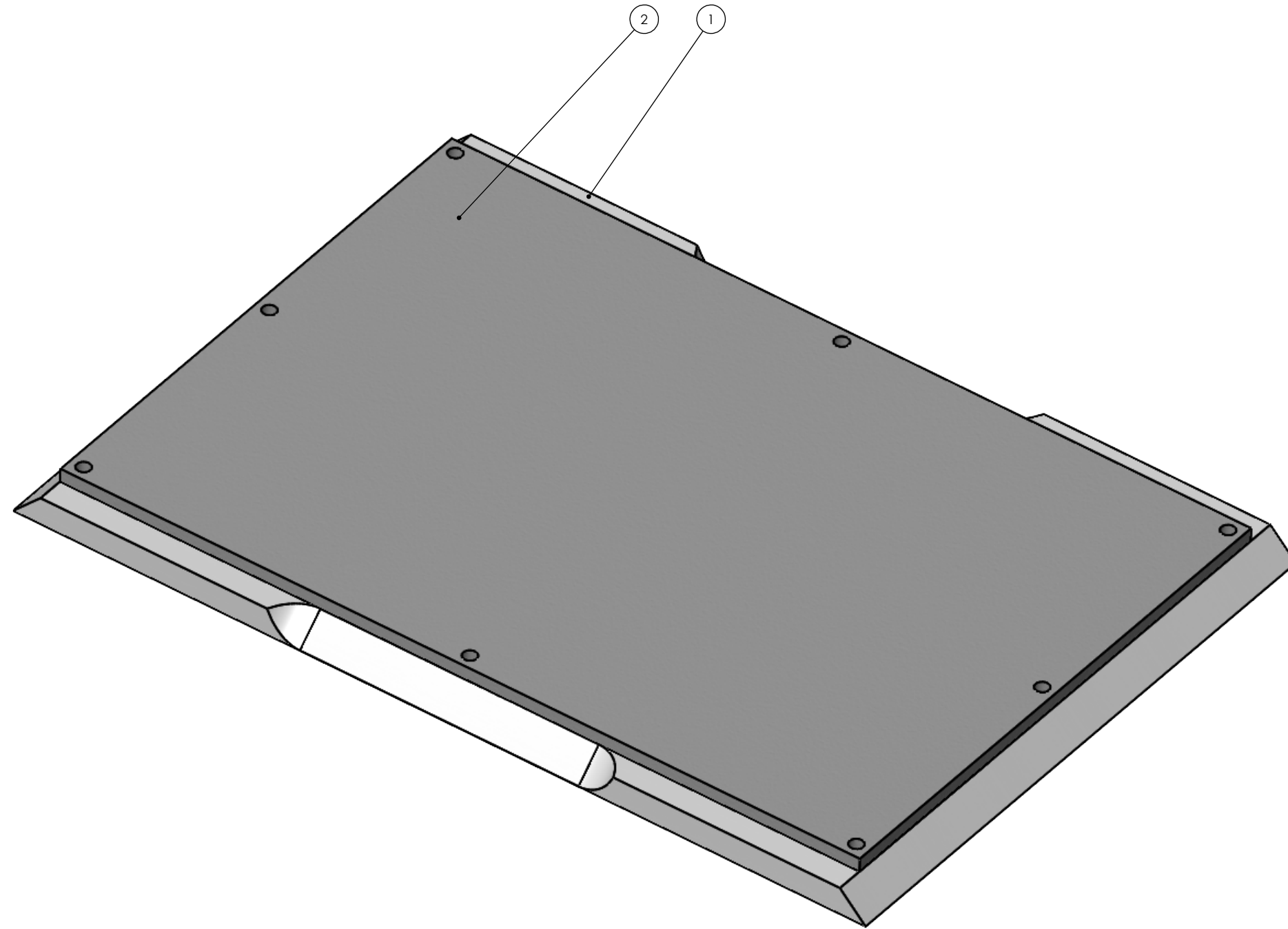

PROPRIETARY AND CONFIDENTIAL
 THE INFORMATION CONTAINED IN THIS DRAWING IS THE SOLE PROPERTY OF AFM ENGINEERING, INC. ANY REPRODUCTION IN PART OR AS A WHOLE WITHOUT THE WRITTEN PERMISSION OF AFM ENGINEERING INC. IS PROHIBITED.

		DIMENSIONS ARE IN INCHES		NAME		DATE	
		TOLERANCES:		DRAWN		-	
		FRACTIONAL ±		CHECKED		-	
		ANGULAR: MACH ± BEND ±		ENG APPR.			
		TWO PLACE DECIMAL ± .010		MFG APPR.			
		THREE PLACE DECIMAL ± .005		Q.A.			
		MATERIAL		COMMENTS:			
NEXT ASSY	USED ON	FINISH					
APPLICATION		DO NOT SCALE DRAWING					
AFM Engineering, Inc.							
AFM Engineering, Inc							
10"X15" Dovetail with Steel Hot Plate							
AFM PART # 105278							
SIZE	DWG. NO.				REV.		
B	59156-000_Steel_Hot_Plate						
SCALE: 1:4				WEIGHT: 9.507		SHEET 1 OF 1	